

REDLINE WALK BEHIND ROLLER

RW 750 D

Technical Data

Masses	
Operating mass	745 kg
Basic Weight	715 kg
Compaction	
Static linear load (front/rear)	5.5 kg/cm
Nominal amplitude	0.4 mm
Centrifugal force	22 kN
Vibration frequency	60 Hz
Engine	
Manufacturer/Model	Kohler KD441
Type	Air-cooled, Diesel
Rated power	6.6 kW @ 2830 rpm
Electrical system	12 V
Tank Capacity	
Fuel tank capacity	5 l
Hydraulic tank capacity	14 l
Water tank capacity	58 l
Traction	
Speed range	0 - 4.5 km/h
Theoretical max. gradability	35 %
Dimensions	
Drum width W	650 mm
Width B	720 mm
Height H1	1350 mm
Height with the handle locked	1,725 mm
Clearance K	210 mm
Drum diameter	400 mm
Length L/L1	1986 mm /2165 mm
	500 mm



Benefits

- Infinitely variable machine speed control
- Hydrostatic Parking brake system Delivers peace of mind on even the steepest terrain
- Optional lighting for night visibility
- Double your comfort and control with our advanced vibration reduction
- Single-point lifting for easy transportation
- Innovative start and stop control simplify your workflow seamlessly
- The easy-to-clean sprinkling system and accessibility to the service points reduce downtime
- Back-up drive protection on the steering handle
- Vibration and throttle
- Two Scraper on each drum
- Keyless electric starter system
- One Point lift

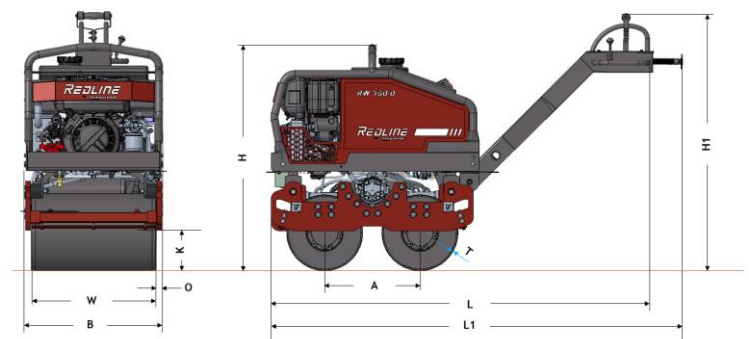

We reserve right to change specifications without notice. Photos and illustrations do not always show standard versions of machines.

The above information is a general description only, all information are supplied without liability.

