



## DRF25 - 60W



### Technical Data

| Dimensions                      |  | Engine                          |   |
|---------------------------------|--|---------------------------------|---|
| Transport width incl. DRV60     | 3 m  | Type                            | 6 cylinder watercooled diesel engine with hydrostatic fan drive             |
| Transport length                | 6.1 m  | Manufacturer                    | Cummins   |
| Transport height                | 3.10 m   | Type                            | QSB 6.7 - C173  |
| Max. working width              | 6.7 m  | Rated power                     | 129kW (175hp) @2200 rpm   |
| Weight incl. DRV60 TVE          | 17.5 t   | Emissions according to          | Tier 3  |
| Weight incl. DRV51 TVE          | 17.2 t   | Electrical system               | 24V   |
|                                 |  | Fuel tank capacity              | 315 L   |
| Capacity                        |  | Undercarriage                   |   |
| Theoretical placement capacity  | 650 t/h  | Final Drive                     | Direct drive over transmissions   |
| Placement thickness (max)       | 300 mm   | Tyre size                       | 445/80R25   |
| Max. paving level below zero    | -100 mm  | Front wheels                    | 4 x 560/300 - 390   |
| Material hopper                 |  | Wheel drive                     | 2 x rear wheels, 2 x front wheels   |
| Capacity                        | 6 m³   | Turning radius (inside)         | 2.48 m  |
| Dumping height (center/outside) | 555/590 mm   | Turning radius (outside)        | 6.07 m  |
| Seperate hopper control         | Yes  | Maximum paving speed            | 30 m/min  |
|                                 |  | Transport speed                 | 15 km/h   |
| Conveyor                        |  | Front ramp angle                | 17°   |
| Conveyor type                   | Dual bar feeder  | Auger                           |   |
| Conveyor width                  | 2 x 580 mm   | Auger diameter                  | 380 mm  |
| Conveyor control                | 2 independent conveyors with limit switches and speed control    | Auger height adjustment         | Mechanic  |
|                                 |  | Auger control                   | 2 independent augers with Ultrasonic sensor and proportional speed control. |
| Operation                       |  | Reversible rotational direction | Yes   |
| Operator console                | Ergonomic dashboard with toggle switches, Slideable left / right | Auger height adjustment         | Infinitely variable by 250mm  |
| Platform                        | Dual seat concept with foldable canopy                           |                                 |   |

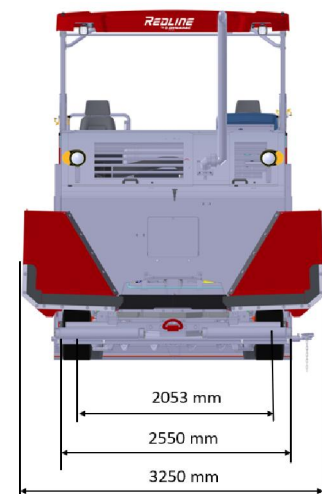
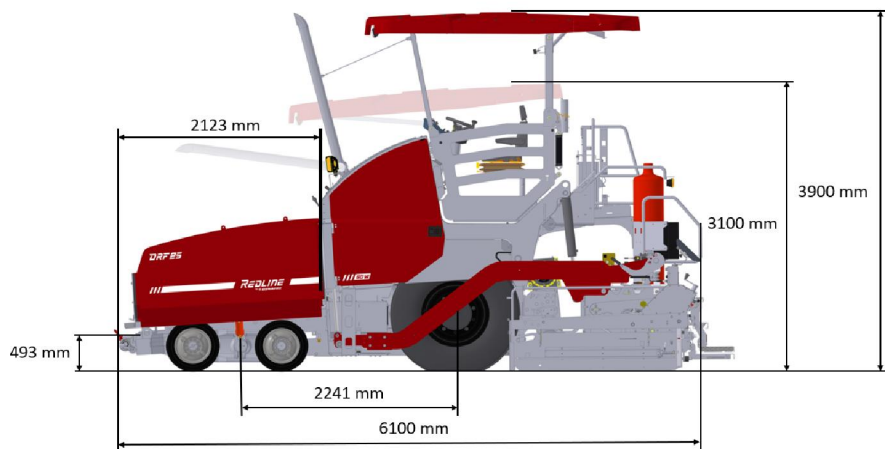

| Screeds  | Basic width | Hydr. Extendable up to | Max. working width | Compaction       | Heating  | Weight  |
|----------|-------------|------------------------|--------------------|------------------|----------|---------|
| DRV51TVE | 2.55 m      | 5.10 m                 | 6.6 m              | Tamper Vibration | Electric | 3400 kg |
| DRV60TVE | 3.00 m      | 6.00 m                 | 6.7 m              | Tamper Vibration | Electric | 3850 kg |

We reserve the right to change specifications without notice. Photos and illustrations do not always show standard versions of machines.

The above information is a general description only, all information are supplied without liability.