

SK130



Note: This catalog may contain attachments and optional equipment that are not available in your area. And it may contain photographs of machines with specifications that differ from those of machines sold in your areas. Please consult your nearest KOBELCO distributor for those items you require. Specialist equipment is needed to use this machine in demolition work. Before using it please contact your KOBELCO dealer. Due to our policy of continuous product improvements all designs and specifications are subject to change without advance notice. Copyright by **KOBELCO CONSTRUCTION MACHINERY CO., LTD.** No part of this catalog may be reproduced in any manner without notice.

KOBELCO CONSTRUCTION MACHINERY CO., LTD.
5-15, Kitashinagawa 5-chome, Shinagawa-ku, Tokyo 141-8626 JAPAN
Tel: +81 (0) 3-5789-2146 Fax: +81 (0) 3-5789-2135
www.kobelcocm-global.com

Inquiries To:

To cities, forests, and all kinds of sites around the world.



Kobelco's innovations have created "earth-friendly construction machines" that play important roles at a diverse range of construction sites throughout the world.

They increase productivity on all types of projects thanks to their power, durability, and outstanding fuel efficiency.

While boasting low fuel consumption, the SK130-10 is state-of-the-art machine that achieve even greater efficiency.

Featuring strong durability and easy maintenance, it's put to powerful use on all kinds of construction sites.

It's high performance exceeds expectations.

Kobelco is focused on the future of the global environment, striving to provide greater work efficiency and reduce life-cycle costs, as well as offering a new sense of value that's ahead of the times.



SK130

More operable. Durable. Better performance.



Upper Structure

Cooling System NEW



The oil cooler has been changed from a two-layer to a one-layer type. This prevents dust from collecting in the gaps, helping to maintain the cooling function.

Improved Workability

Speedy combined operations

Combined attachment operations, such as horizontal pulling to operate the boom and arm at the same time, are also nimble and smooth, making it possible to work faster.

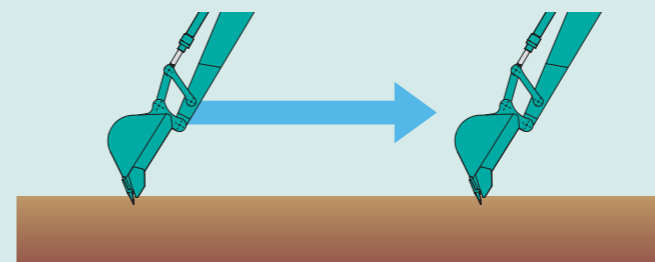

Travel System

Reinforced Guide Frame

Reinforced guide frame prevents deformation caused by impact or encroaching of loose stones.



Get More Done Faster with Superior Operability

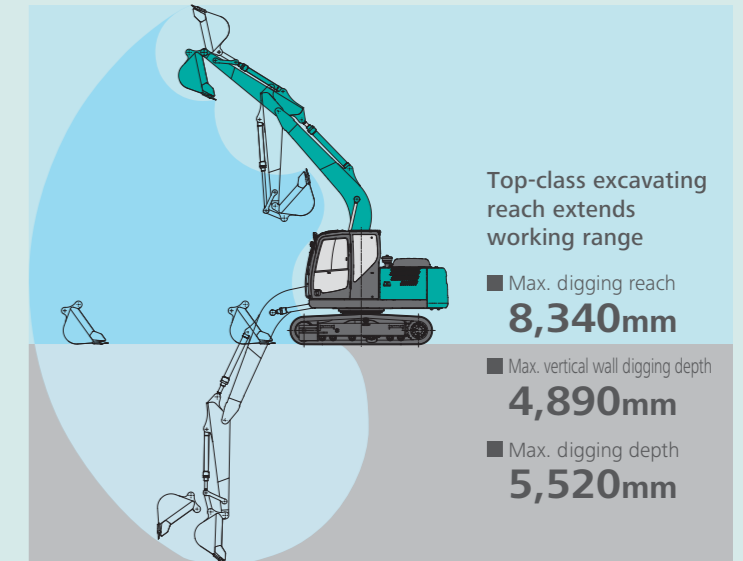

*1 Values are for STD arm (2.38m)
*2 Without including height of shoe

Attachment/Equipment

Reinforced Attachments

There is a new long arm. Additionally, lock guard reinforcement can now be attached to the tip. The shape of the lower plate has been optimized for logging work, and the arm strength is enhanced.

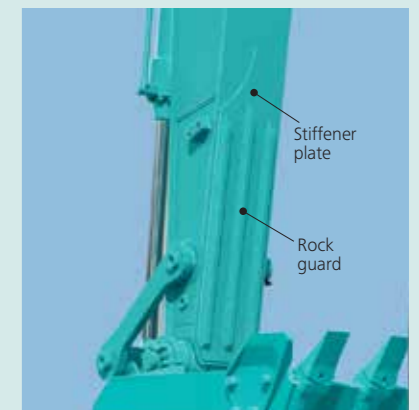

Reinforced Undercover

Reinforced undercover protects the piping and other components from damage caused by accidental contact with branches, debris and other obstacles.



We're always pursuing fuel efficiency.

Efficient maintenance to sustain high performance.

Reduced fuel consumption in ECO-mode

ECO-mode: Engineered for Economy NEW

Kobelco's ECO-mode maximizes the operating efficiency of the engine and other components to achieve much greater fuel efficiency. Just press a button to choose the operation mode best suited to the task at hand and the working conditions.

Optimal operation with three modes

H-mode • • • Maximum power for maximum productivity on your toughest jobs

S-mode • • • Ideal balance of productivity and fuel efficiency for a range of urban engineering projects

ECO-mode • • • Minimum fuel consumption for utility projects and other work that demands precision

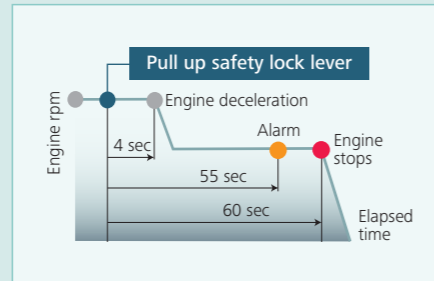

AIS (Auto Idle Stop)

If the safety lock lever is lifted up, the engine will stop automatically. This eliminates wasteful idling during standby, saving fuel and reducing CO₂ emissions as well.

Hydraulic system engineered to reduce energy loss

Kobelco's proprietary hydraulic systems offer hydraulic line positioning that reduces friction resistance and valves designed for higher efficiency, minimizing energy loss throughout the system.

Always and forever. Yesterday, today, and tomorrow. We're obsessed with fuel efficiency

Our new ECO-mode is 20% more fuel efficient than the SK130-8 H-mode.

Operator-friendly Features Include Controls that Are Easy to See, Easy to Use



Multi-Display in Color NEW

Brilliant colors and graphic displays are easy to recognize on the LCD multi-display in the console. The display shows fuel consumption, maintenance intervals, and more.

- 1 Analog gauge provides an intuitive reading of fuel level and engine water temperature
- 2 Green indicator light shows low fuel consumption during operation
- 3 Fuel consumption/Switch indicator for rear camera images
- 4 Digging mode switch
- 5 Monitor display switch

One-Touch Attachment Mode Switch

A simple touch of a button, switches the hydraulic circuit and flow amount to match attachment changes. Icons help the operator to confirm the proper configuration at a glance.

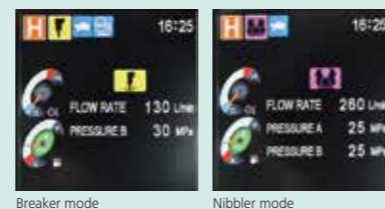
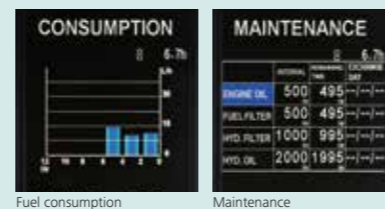

Compatible with Biofuel

Biofuel may be used with Kobelco machinery, reducing environmental impact and supporting business. *For more information about using biofuels, please contact the nearest dealer.

Maintenance Work, Daily Checks, Etc., Can Be Done from Ground Level

The layout allows for easy access from the ground for many daily checks and regular maintenance tasks.



Simple layout for easy access to radiator and cooling system elements

- 1 Pre-filter (with built-in water separator)
- 2 Pilot Line Filter
- 3 Main fuel filter
- 4 Third filter



An enlarged cartridge-type pilot filter simplifies maintenance.

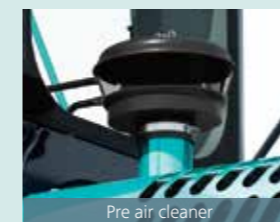

More Efficient Maintenance Inside the Cab



Internal and external air conditioner filters can be easily removed without tools for cleaning.

Easy Cleaning

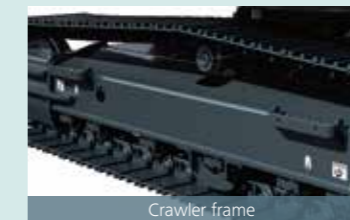

Special crawler frame design for easy mud removal cleaning.



Detachable two-piece floor mat with handles for easy removal. A floor drain is located under floor mat.



Floor mat's raised edges help keep the cab floor free of mud, simplify cleaning.



Engine oil pan equipped with drain valve.



Examples of displaying maintenance information

Machine Information Display Function

- Displays only the maintenance information that's needed, when it's needed
- Self-diagnostic function provides early-warning detection and display of electrical system malfunctions
- Service-diagnostic function makes it easier to check the status of the machine
- Record function of previous breakdowns including irregular and transient malfunction

Long-life hydraulic oil:
2,000 hours

Long-Interval Maintenance

Long-life hydraulic oil reduces cost and labor.

Replacement cycle:
1,000 hours

Highly Durable Premium-fine Filter

The high-capacity hydraulic oil filter incorporates glass fiber with superior cleaning power and durability.



Comfortable Cab Is Now Safer than Ever.

A work environment that is quieter and more comfortable. A cab that puts the operator first is key to improved safety.



*Prevention bar shall be equipped on the right side window.



*Prevention bar shall be equipped on the right side window.

Comfort

Super-Airtight Cab



The high level of air-tightness keeps dust out of the cab.

Quiet Inside

The high level of air-tightness ensures a quiet, comfortable cabin interior.

Low Vibration

Coil springs absorb small vibrations, and high suspension mounts filled with silicone oil reduce heavy vibration. The long stroke achieved by this system provides excellent protection from vibration.

Twice the stroke of a conventional mount



Anti-theft measures

Theft-prevention brackets have been installed on the ECU, mechatronics, and cluster panels. Their structure makes removal very difficult.



Broad View Liberates the Operator

The front window features one large piece of glass without a center pillar on the right side for a wide, unobstructed view.

Air Conditioner Louvers behind the Seat



The large air-conditioner has louvers on the back pillars that blow from behind and to the right and left of the operator's seat. They can be adjusted to put a direct flow of cool/warm air on the operator, which means a more comfortable operating environment.

More Comfortable Seat Means Higher Productivity



Seat recliner can be pushed back flat



Double slides allow adjustment for optimum comfort

*Armrests are equipped with suspension seats only.



Large Cab Is Easy to Get in and Out of

The expanded cab provides plenty of room for a large door, more headroom and smoother entry and exit.

*Prevention bar shall be equipped on the right side window.

Interior Equipment Adds to Comfort and Convenience



Spacious storage tray



Large cup holder

Safety

ROPS Cab

ROPS (Roll-Over-Protective Structure)-compliant cab clears ISO standards (ISO-12117-2: 2008) and ensures greater safety for the operator should the machine tip over.



Expanded Field of View for Greater Safety



Rearview mirrors left and right

Greater safety assured by rearview mirrors on left and right.

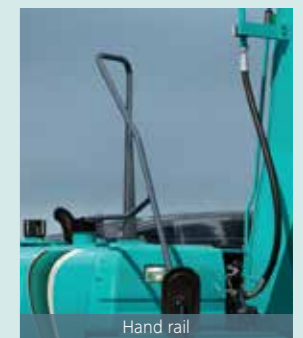

Hand rail



Prevention bar for leaning out of window

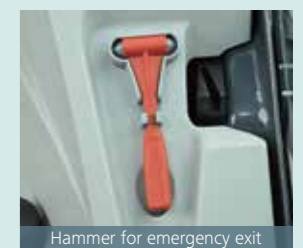

Hammer for emergency exit



Remote Monitoring for Peace of Mind

KOMEXS uses satellite communication and internet to relay data, and therefore can be deployed in areas where other forms of communication are difficult. When a hydraulic excavator is fitted with this system, data on the machine's operation, such as operating hours, location, fuel consumption, and maintenance status can be obtained remotely.

Direct Access to Operational Status

Location Data

Accurate location data can be obtained even from sites where communications are difficult.

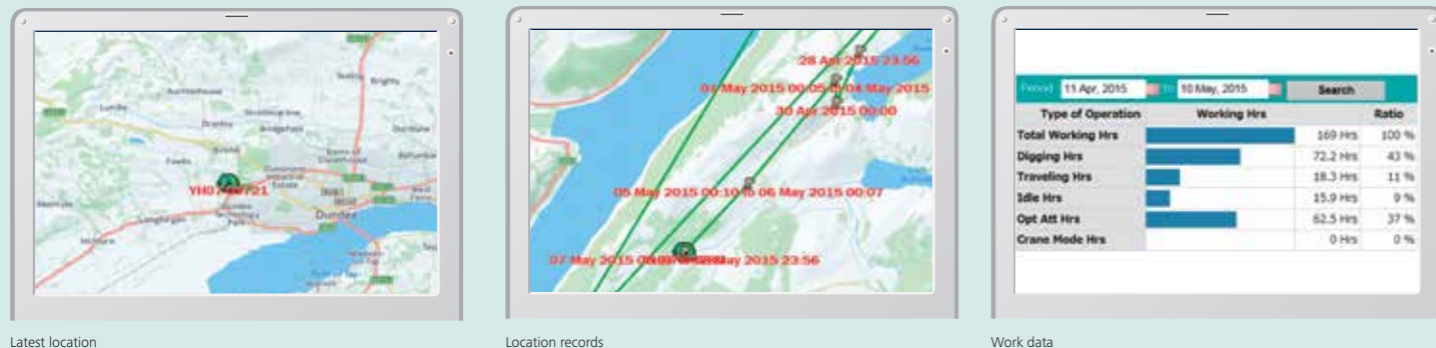

Latest location

Location records

Work data

Operating Hours

- A comparison of operating times of machines at multiple locations shows which locations are busier and more profitable.
- Operating hours on site can be accurately recorded, for running time calculations needed for rental machines, etc.

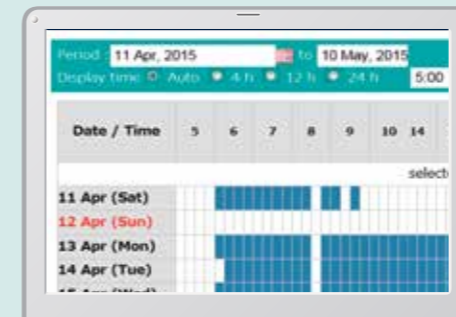

Daily report

Fuel Consumption Data

- Data on fuel consumption and idling times can be used to indicate improvements in fuel consumption.

Work mode	Working Hrs	Total Fuel Consumption
H mode	2:06	24.5 L
S mode	0:00	0.0 L
E mode	169:19	1489.7 L
TOTAL	171:25	1514.2 L

Fuel consumption

Graph of Work Content

- The graph shows how working hours are divided among different operating categories, including digging, idling, travelling and optional operations.



Work status

Maintenance Data and Warning Alerts

Machine Maintenance Data

- Provides maintenance status of separate machines operating at multiple sites.
- Maintenance data is also relayed to KOBELCO service personnel, for more efficient planning of periodic servicing.

Model	Serial No.	Hour Meter	Engine Oil
SK135SRLC-3/SK140SRL	YH07-09721	734 Hr	434
SK135SRLC-3/SK140SRL	YH07-09789	73 Hr	429
SK210LC-9	YQ13-10454	960 Hr	58
SK210LC-9	YQ13-10481	549 Hr	498
SK75SR-	YT08-30174		

Maintenance

Warning Alerts

- This system gives an alert if an anomaly is sensed, preventing damage that could result in machine downtime.

Alarm Information Can Be Received via E-mail

- Alarm information or maintenance notice can be received via e-mail, using a computer or a mobile device.



Alarm messages can be received on a mobile device.

Daily/Monthly Reports

- Operational data downloaded onto a computer helps in formulating daily and monthly reports.

Security System

Engine Start Alarm

- The system can be set up with an alarm if the machine is operated outside designated time.



Engine start alarm outside prescribed work time

Area Alarm

- It can be set up with an alarm if the machine is moved out of its designated area to another location.



Alarm for outside of reset area

Engine

Model	MITSUBISHI D04FR-74kW
Type	Water-cooled, 4 cycle 4 cylinder direct injection type diesel engine with intercooler turbo-charger
No. of cylinders	4
Bore and stroke	102 mm x 130 mm
Displacement	4.249 L
Rated power output	69.2 kW / 2,000 min ⁻¹ (ISO 9249: with fan)
	74 kW / 2,000 min ⁻¹ (ISO 14396: without fan)
Max. torque	359 N·m / 1,600 min ⁻¹ (ISO 9249: with fan)
	375 N·m / 1,600 min ⁻¹ (ISO 14396: without fan)

Hydraulic System

Pump	
Type	Two variable displacement pumps + one gear pump
Max. discharge flow	2 x 130 L/min, 1 x 20 L/min
Relief valve setting	
Boom, arm and bucket	34.3 MPa {350 kgf/cm ² }
Travel circuit	34.3 MPa {350 kgf/cm ² }
Swing circuit	28.0 MPa {296 kgf/cm ² }
Control circuit	5.0 MPa {50 kgf/cm ² }
Pilot control pump	Gear type
Main control valve	12-spool
Oil cooler	Air cooled type

Swing System

Swing motor	Axial piston motor
Brake	Hydraulic; locking automatically when the swing control lever is in neutral position
Parking brake	Oil disc brake, hydraulic operated automatically
Swing speed	11 min ⁻¹ {rpm}
Tail swing radius	2,180 mm
Min. front swing radius	2,640 mm

Attachments

Backhoe bucket and combination

Type	Backhoe bucket				
Bucket capacity	ISO heaped	m ³	0.45	0.50	0.57
	ISO Struck	m ³	0.35	0.38	0.43
Opening width	With side cutter	mm	940	1,000	1,100
	Without side cutter	mm	840	900	1,000
No. of teeth			4	5	5
Bucket weight		kg	350	380	400
Combination	2.38 m arm (with rock guard)	○	◎	△	
	2.84 m arm	◎	△	-	

◎ Standard combination ○ Recommended △ Loading only - Not applicable

Travel System

Travel motors	2 x axial-piston, two-step motors
Travel brakes	Hydraulic brake per motor
Parking brakes	Oil disc brake per motor
Travel shoes	44 each side
Travel speed	5.8 / 3.4 km/h
Drawbar pulling force	142 kN (14,500 kgf) SAE J 1309
Gradeability	70 % {35°}

Cab & Control

Cab	
All-weather, sound-suppressed steel cab mounted on the high suspension mounts filled with silicone oil and equipped with a heavy, insulated floor mat.	
Control	
Two hand levers and two foot pedals for travel	
Two hand levers for excavating and swing	
Electric rotary-type engine throttle	

Boom, Arm & Bucket

Boom cylinders	100 mm x 1,092 mm
Arm cylinder	115 mm x 1,116 mm
Bucket cylinder	95 mm x 903 mm

Refilling Capacities & Lubrications

Fuel tank	271 L
Cooling system	16 L
Engine oil	18.5 L
Travel reduction gear	2 x 2.1 L
Swing reduction gear	1.65 L
Hydraulic oil tank	104 L tank oil level
	160 L hydraulic system

Working Ranges

Range	4.68 m	
	2.38m	2.84m
a- Max. digging reach	8.34	8.78
b- Max. digging reach at ground level	8.19	8.64
c- Max. digging depth	5.52	5.98
d- Max. digging height	8.50	8.80
e- Max. dumping clearance	6.09	6.39
f- Min. dumping clearance	2.23	1.80
g- Max. vertical wall digging depth	4.89	5.35
h- Min. swing radius	2.64	2.80
i- Horizontal digging stroke at ground level	4.18	4.67
j- Digging depth for 2.4 m (8') flat bottom	5.29	5.79
Bucket capacity ISO heaped m ³	0.50	0.50

Digging Force (ISO 6015)		
Unit: kN		
Arm length	2.38m	2.84m
Bucket digging force	90.4	90.4
Arm crowding force	64.1	58.1

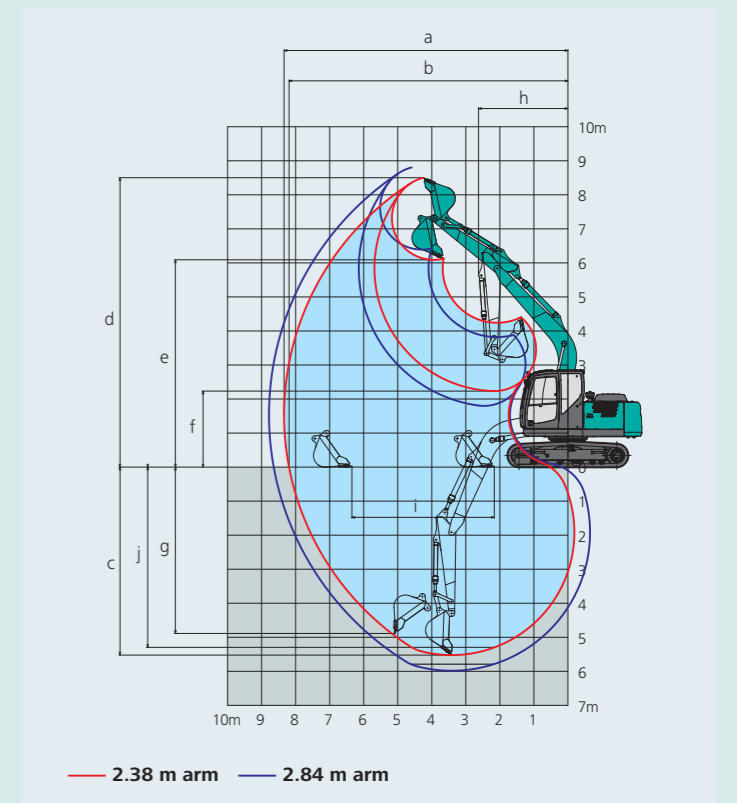

Dimensions

Arm length	2.38m	2.84m
A Overall length	7,800	7,790
B Overall height (to top of boom)	2,730	3,120
C Overall width of crawler	2,490	2,490
D Overall height (to top of cab)	2,870	2,870
E Ground clearance of rear end*	860	860
F Ground clearance*	415	415
G Tail swing radius	2,180	2,180

Unit: mm			
G'	Distance from center of swing to rear end	2,180	2,180
H	Tumbler distance	2,870	2,870
I	Overall length of crawler	3,580	3,580
J	Track gauge	1,990	1,990
K	Shoe width	500	500
L	Overall width of upperstructure	2,490	2,490

*Without including height of shoe lug

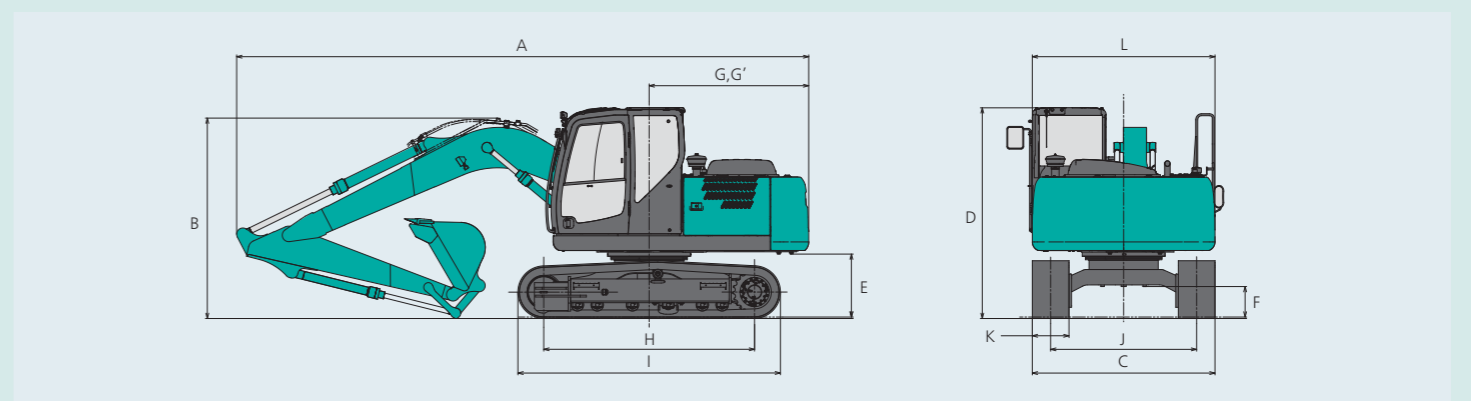

Operating Weight & Ground Pressure

In standard trim, with standard boom, 2.38 m arm, and 0.50 m³ ISO heaped bucket

Shaped	Grouser shoes (even height)		
Shoe width	mm	500	700
Overall width of crawler	mm	2,490	2,690
Ground pressure		41	30
Operating weight		13,000	13,500

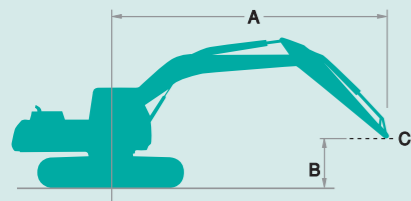

Rating over front

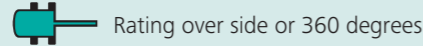

Rating over side or 360 degrees

A: Reach from swing centerline to arm top
 B: Arm top height above/below ground
 C: Lift point
 Bucket: Without bucket
 Relief valve setting: 34.3 MPa (350 kgf/cm²)

SK130		Arm: 2.38 m Bucket: Without, Shoe: 500 mm Counterweight: 2.400 kg										
B	A	1.5 m		3.0 m		4.5 m		6.0 m		At Max. Reach		Radius
		Rating over front	Rating over side or 360 degrees	Rating over front	Rating over side or 360 degrees	Rating over front	Rating over side or 360 degrees	Rating over front	Rating over side or 360 degrees	Rating over front	Rating over side or 360 degrees	
6.0 m	kg					*3,250	*3,250			*1,820	*1,820	5.47 m
4.5 m	kg					*3,530	*3,530	3,250	2,240	*1,680	*1,680	6.44 m
3.0 m	kg			*6,300	6,250	*4,380	3,350	3,160	2,160	*1,670	*1,670	6.96 m
1.5 m	kg			*5,630	5,510	4,700	3,100	3,050	2,060	*1,760	1,590	7.11 m
G.L.	kg			*6,080	5,290	4,520	2,930	2,960	1,980	*1,980	1,620	6.93 m
-1.5 m	kg	*5,200	*5,200	8,960	5,290	4,460	2,880	2,940	1,960	*2,420	1,800	6.40 m
-3.0 m	kg	*8,950	*8,950	*7,870	5,420	4,520	2,940			3,490	2,320	5.39 m

SK130		Arm: 2.84 m Bucket: Without, Shoe: 500 mm Counterweight: 2,400 kg												
B	A	1.5 m		3.0 m		4.5 m		6.0 m		7.5 m		At Max. Reach		Radius
		Rating over front	Rating over side or 360 degrees	Rating over front	Rating over side or 360 degrees	Rating over front	Rating over side or 360 degrees	Rating over front	Rating over side or 360 degrees	Rating over front	Rating over side or 360 degrees	Rating over front	Rating over side or 360 degrees	
7.5 m	kg											*2,070	*2,070	4.49 m
6.0 m	kg							*1,870	*1,870			*1,710	*1,710	6.04 m
4.5 m	kg							*3,060	2,250			*1,590	*1,590	6.93 m
3.0 m	kg			*5,290	*5,290	*3,940	3,390	3,160	2,160			*1,580	1,510	7.41 m
1.5 m	kg			*8,130	5,610	4,710	3,100	3,030	2,030	*1,960	1,430	*1,660	1,420	7.55 m
G.L.	kg			*6,310	5,230	4,480	2,890	2,920	1,930			*1,840	1,430	7.39 m
-1.5 m	kg	*4,450	*4,450	*8,650	5,170	4,380	2,810	2,870	1,890			*2,190	1,570	6.89 m
-3.0 m	kg	*7,530	*7,530	*8,370	5,260	4,410	2,830					2,940	1,940	5.96 m
-4.5 m	kg			*5,960	5,520							*3,800	3,170	4.34 m

- Notes:**
- Do not attempt to lift or hold any load that is greater than these lift capacities at their specified lift point radius and heights. Weight of all accessories must be deducted from the above lift capacities.
 - Lift capacities are based on machine standing on level, firm, and uniform ground. User must make allowance for job conditions such as soft or uneven ground, out of level conditions, side loads, sudden stopping of loads, hazardous conditions, experience of personnel, etc.
 - Arm top defined as lift point.
 - The above lift capacities are in compliance with ISO 10567. They do not exceed 87% of hydraulic lift capacity or 75% of tipping load. Lift capacities marked with an asterisk (*) are limited by hydraulic capacity rather than tipping load.
 - Operator should be fully acquainted with the Operator's and Maintenance Instructions before operating this machine. Rules for safe operation of equipment should be adhered to at all times.
 - Lift capacities apply to only machine originally manufactured and normally equipped by KOBELCO CONSTRUCTION MACHINERY CO., LTD.

STANDARD EQUIPMENT

ENGINE

- Engine, MITSUBISHI D04FR-74KW, diesel engine with turbocharger and intercooler
- Automatic engine deceleration
- Auto Idle Stop (AIS)
- Batteries (2 x 12V - 100Ah)
- Starting motor (24V - 5 kW), 50 amp alternator
- Automatic engine shut-down for low engine oil pressure
- Engine oil pan drain cock
- Double element air cleaner

CONTROL

- Working mode selector (H-mode, S-mode and ECO-mode)

SWING SYSTEM & TRAVEL SYSTEM

- Swing rebound prevention system
- Straight propel system
- Two-speed travel with automatic shift down
- Sealed & lubricated track links
- Grease-type track adjusters
- Automatic swing brake

HYDRAULIC

- Arm regeneration system
- Aluminum hydraulic oil cooler

MIRRORS & LIGHTS

- Three rear view mirrors
- Three front working lights (one for boom, one for right storage box, and one for Cab)

CAB & CONTROL

- Two control levers, pilot-operated
- Horn, electric
- Cab light (interior)
- Luggage tray
- Large cup holder
- Detachable two-piece floor mat
- Headrest
- Handrails
- Intermittent windshield wiper with double-spray washer
- Skylight
- Tinted safety glass
- Pull-up type front window and removable lower front window
- Easy-to-read multi-display color monitor
- Automatic air conditioner
- Emergency escape hammer
- KOMEXS

OPTIONAL EQUIPMENT

- Two cab lights
- N & B piping
- Wide range of buckets
- Various optional arms
- Wide range of shoes
- Suspension seat
- Multi control valve
- Suspension seat with armrest

Note: Standard and optional equipment may vary. Consult your KOBELCO dealer for specifics.